

ideal
HEATING

Logic Air monobloc heat pump.

4kW - 10kW



idealheating.com

Decarbonisation of domestic heating.

Decarbonisation and the drive towards Net Zero by 2050 is fast becoming a reality, with the UK government committing to a national target of Net Zero carbon emissions by 2050. This means the way we provide heating and hot water to homes will fundamentally change over the coming years.

The Logic Air heat pump takes all the experience we have across the globe and throughout Europe to deliver heat pump technology that works and provides optimum comfort and efficiency. The Ideal heat pump package combines three revolutionary products:

- 1. Our quiet, compact and highly efficient monobloc heat pump**
- 2. Our industry leading pre-plumbed heat pump cylinder**
- 3. The Halo Air heat pump thermostat**

Our heat pumps are designed to work in new build and retrofit installations, working with traditional radiators and underfloor heating.

Contents

- 4** - Introduction
- 5** - The ideal heat pump ecosystem
- 6** - Logic Air heat pump
- 10** - Logical solutions
- 12** - The technology
- 13** - COP & SCOP
- 14** - Logic Air pre-plumbed cylinder
- 24** - Logic Air control box
- 26** - Accessories list
- 28** - Halo Air
- 38** - Product codes
- 40** - Designed for new builds
- 41** - Designed for home owners
- 42** - Designed for installers
- 43** - Benefits of working with Ideal
- 44** - World-class support



Introduction, background and collaboration.

Whilst we may be best known for gas boilers in the UK, behind the scenes there is a wealth of expertise reaching across the globe supporting the **low carbon transformation** that is coming to the UK heating industry.

Our parent company, Groupe Atlantic, a family-owned global HVAC manufacturer, has a long history in heat pumps and currently holds a market leading position in France. Combining the Groupe Atlantic heat pump technical and manufacturing expertise with our knowledge of UK heating systems and the UK market provides a **winning formula for the launch of our first monobloc heat pump range.**



In addition, we are also utilising cylinder expertise within the group from Gledhill who manufacture the **high quality, ultra-efficient heat pump cylinder** that complements the monobloc heat pump.

Combining knowledge and skills from Groupe Atlantic, Ideal Heating and Gledhill, we have developed **a range of products that will make our customers lives easier**, just like the award-winning Logic boiler.

As well as the technical and manufacturing expertise, the **new low carbon products** are supported by the industry leading customer support package that we are known for. From SAP and heating design support to technical assistance, over the phone or in person including end user advice, whether the product is a heat pump or a gas boiler, we will deliver the same outstanding customer service and support.

Therefore, we are pleased to announce the launch of the Logic Air monobloc heat pump, pre plumbed heat pump cylinder and Halo Air room thermostat.



The Ideal heat pump ecosystem.

The Logic Air range brings our best low carbon products together. Designed to operate seamlessly, our industry leading heat pump, highly efficient hot water cylinder and Halo room thermostat provide all the components

for a reliable and efficient heat pump system. Supported by national customer service and engineer support. The Logic Air range offers the complete low carbon package.

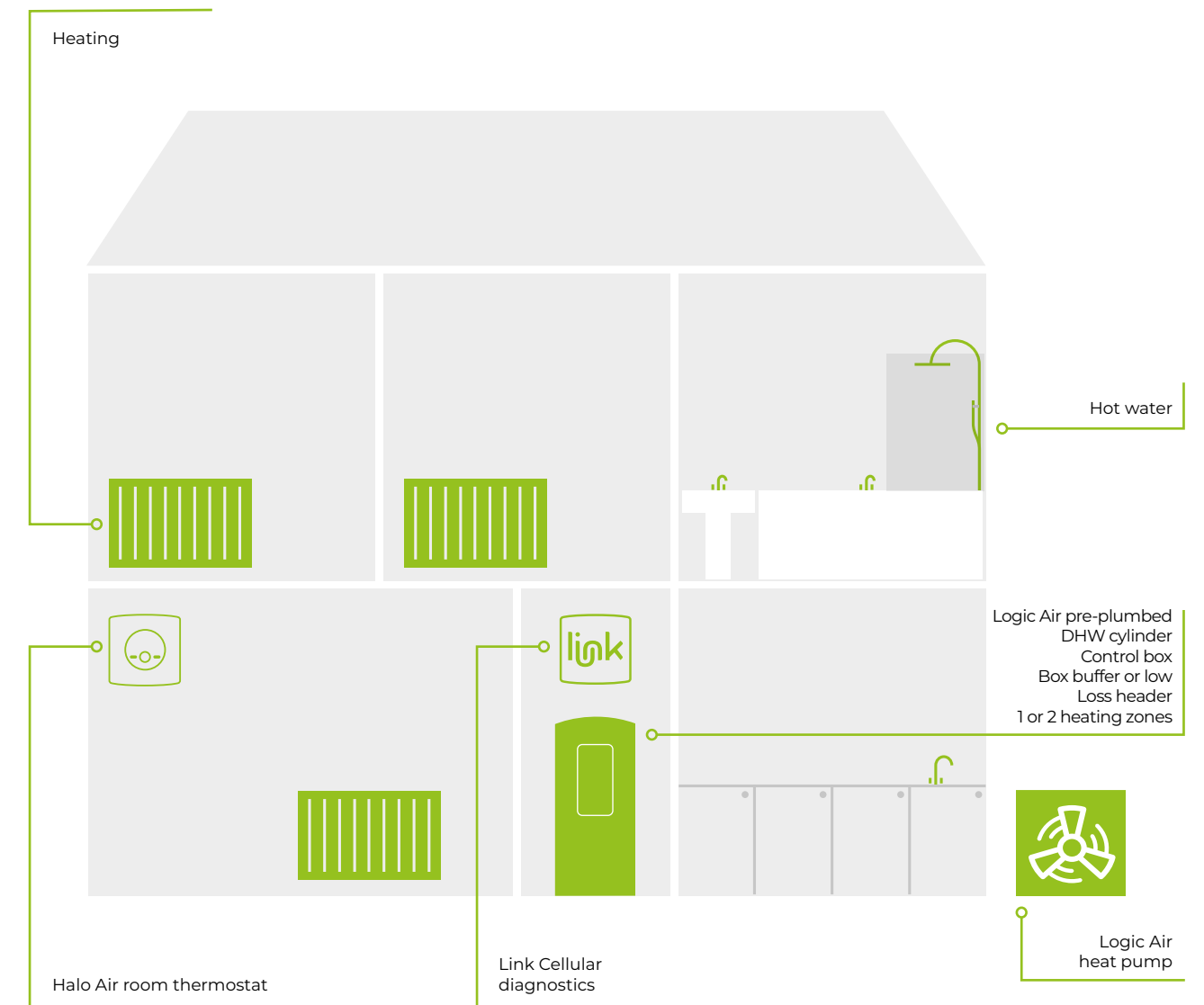

Logic Air heat pump.



KEY FEATURES



Designed for the UK climate



364 days a year UK customer service



Quiet operation



SCOP rating up to 519%*



Hot water in sunshine, rain, ice and snow



All Logic Air heat pumps are Quiet Mark certified



*Performance data in accordance with EN 14825, EN 12102-1, EN 14511. The energy efficiency provided may not correspond to the actual energy once installed in a building, as the efficiency is influenced by other factors such as heat loss in the distribution system and the capacity of the products in relation to building size and characteristics.

Logic Air specification.

The Logic Air heat pump range is our new range of monobloc heat pumps, offering great efficiencies both in heating and hot water. The Logic Air is designed to deliver efficient, simple and reliable low carbon heating in homes throughout the UK.

Taking the learnings from the award winning Logic boiler, the Logic Air heat pump integrates seamlessly with UK homes, partnered with our best in class pre-plumbed hot water cylinder and our connected Halo Air room thermostat, the Logic Air is quick to install, easy to commission and simple to use.

Our new heat pumps are supported by our industry leading customer service and warranty team which is based in the UK and is open 364 days a year, providing customer service and technical support.

DIMENSIONS

	4kW & 5kW	8kW & 10kW
A	798	1008
B	518	518
C	1095	1095
D	499	499
E	518	518
F	558	558
G	688	688
H	516	516
I	80	80
J	184	184
K	140	140
L	95	95
M	84	84
N	48	48
O	90	90
P	103	105

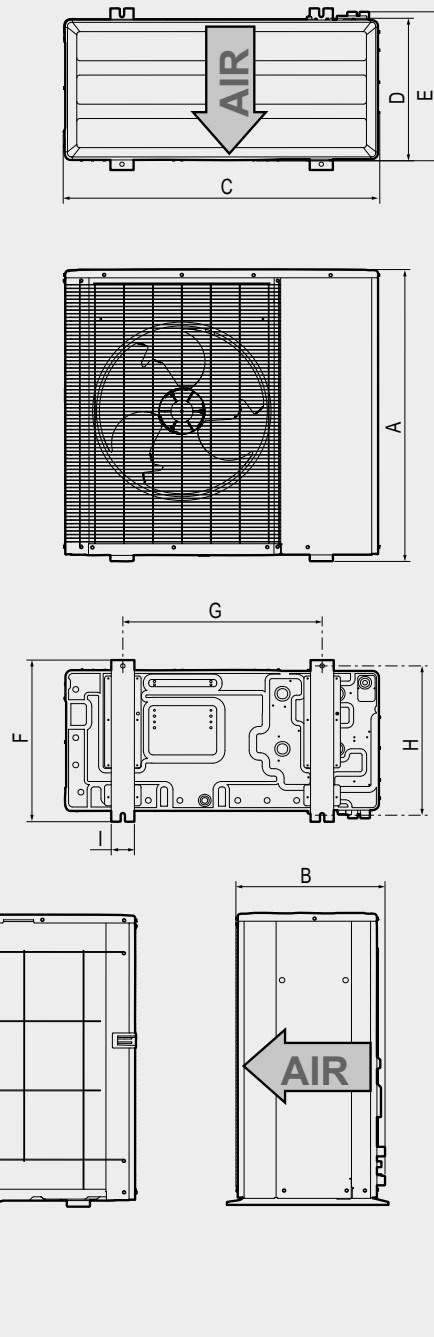

KEY FEATURES

- Quiet operation
- Highly efficient: SCOP up to 5.19*
- Compatibility: radiator and underfloor heating systems
- Intuitive control: smart weather compensating controls
- Low carbon refrigerant: zero ozone depletion and low global warming potential
- Smart grid and solar PV compatible
- Monobloc technology enables easy installation and servicing
- Domestic hot water: hot, efficient and fast re-heat times with the Ideal heat pump cylinder range

INTERNAL DIAGRAM

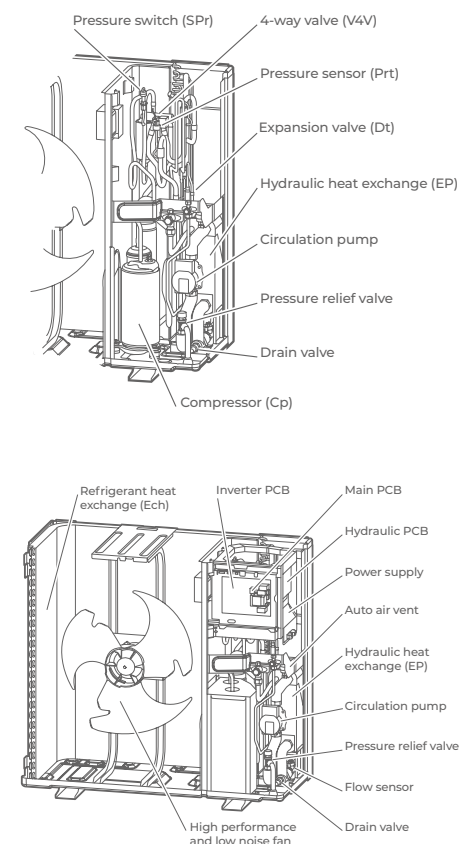

Logic Air specification.

		Logic Air 4kW	Logic Air 5kW	Logic Air 8kW	Logic Air 10kW
Ideal Product Code		AH750664	AH750665	AH750666	AH750667
MCS Certification No.		KIWA 00027/024 HP	KIWA 00027/023 HP	KIWA 00027/021 HP	KIWA 00027/022 HP
Heat Pump Space Heating [35°C]*	ErP Rating	A+++	A+++	A+++	A+++
	ηs	195	200	203	205
	SCOP (EN14825)	4.96	5.07	5.16	5.19
Heat Pump Space Heating [55°C]*	ErP Rating	A++	A++	A++	A++
	ηs	136	143	145	146
	SCOP (EN14825)	3.48	3.65	3.7	3.73
Heating [A 7°C / W 35°C]*	Capacity (kW)	4.0	5.0	8.2	10.3
	Power Input (kW)	0.75	0.97	1.58	2.1
	COP	5.34	5.0	5.19	4.9
Heating [A 7°C / W 55°C]*	Capacity (kW)	4.0	5.0	8.2	10.3
	Power Input (kW)	1.33	1.64	2.67	3.42
	COP	3.00	3.04	3.07	3.01
Sound Power Level (EN 12102 - 1)	35°C db(A)	52	52	55	55
	55°C db(A)	52	52	55	55
Pipework Connection Sizes	Heating F/R (mm)	28mm	28mm	28mm	28mm
Dimensions Outdoor Unit (mm)	Width	1095	1095	1095	1095
	Depth	521	521	518	518
	Height	798	798	1008	1008
Weight (kg)	Outdoor Unit	86	86	110	110
Electrical Data	Electrical Supply (50 Hz)	230v	230v	230v	230v
	Phase	Single Phase	Single Phase	Single Phase	Single Phase
Refrigerant Charge (kg)*	R32	0.88	0.88	1.47	1.47
Certification	EN 14511:2018, EN 14825:2016, EN 12102 - 1:2022				

*Performance data in accordance with EN 14825 : 2016, EN 12102-1:2022, EN 14511 : 2018. The energy efficiency provided may not correspond to the actual energy once installed in a building, as the efficiency is influenced by other factors such as heat loss in the distribution system and the capacity of the products in relation to building size and characteristics.

Logical solutions.



EFFICIENCY

The efficiency rating of a heat pump determines how much it costs to use. A high efficiency rating means it costs less to operate. The Logic Air has one of the highest efficiency ratings in the UK, rated at 5.19 (Coefficient of performance) making it one of the most economical heat pumps on the market.



SOUND AND DIMENSIONS

Sound and dimensions are important, not just for our customers comfort level, but to MCS and the Planning office. The Logic Air is quiet and compact. Small enough for permitted development with the local planning authority and cutting edge acoustic technology makes its low sound levels amongst the best in the market.



FAST HEAT PUMP INSTALLATION

Our Logic Air heat pump, pre-plumbed cylinders and Halo Air room thermostat are designed to be amongst the fastest heat pumps to install. Factory fitted components, click and connect wiring terminals reduce installation time and improve installation reliability.



HOT WATER

Ensuring enough hot water can be generated efficiently and quickly is crucial to a heat pump system. The Logic Air pre-plumbed hot water cylinder can generate hot water faster than some of the most popular heat pump DHW cylinders in the UK, saving money and energy.



SIMPLE TO USE, APP CONTROL AND ONLINE HEALTH CHECKS

Halo Air is a new generation of heat pump thermostats connected to your phone with options to connect to our customer service team. Halo Air automatically makes your heating system more efficient, enables remote control and 24/7 system performance data. All wrapped up in an easy to use controller.



SAFE AS STANDARD

R32 refrigerant has a flammability rating almost 85% lower than propane alternatives. With a '0' ozone depletion rating and a low global warming potential, R32 is safe efficient and reliable.

The technology.

HEAT PUMP CYCLE

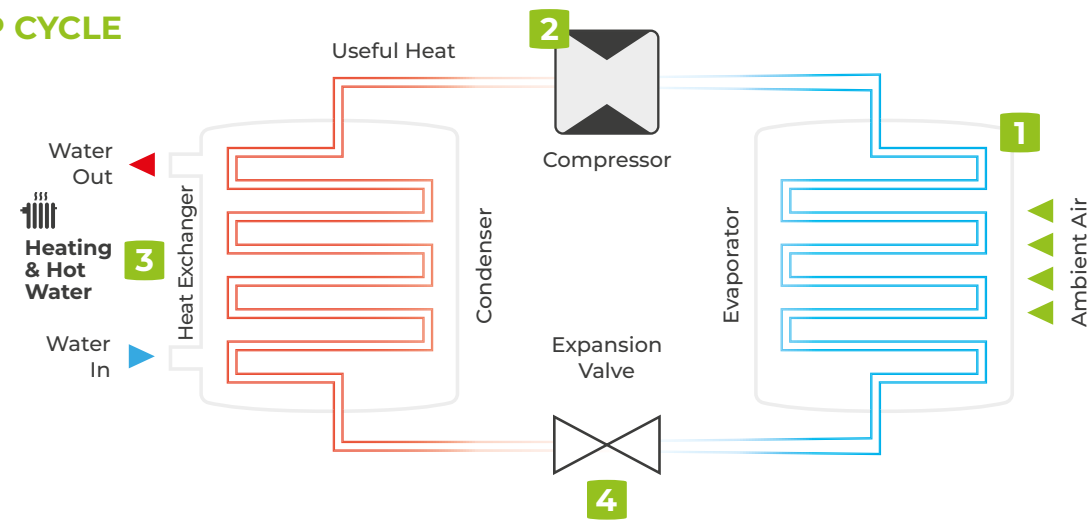

1. CAPTURE

The fan passes ambient air over extremely cold liquid refrigerant. The refrigerant captures the heat from the ambient air and becomes a warm vapour.

2. COMPRESS

The warm refrigerant vapour passes through a compressor which produces hot refrigerant and usable heat.

3. EXCHANGE

The heat in the hot refrigerant is then transferred to the heating and hot water cylinder through a heat exchanger.

4. EXPAND

Once the heat has been transferred to the house, the refrigerant passes through an expansion valve which reduces its temperature, making it really cold again and enabling it to capture heat from the ambient air, continuing the cycle.

Sound pressure and sound power.

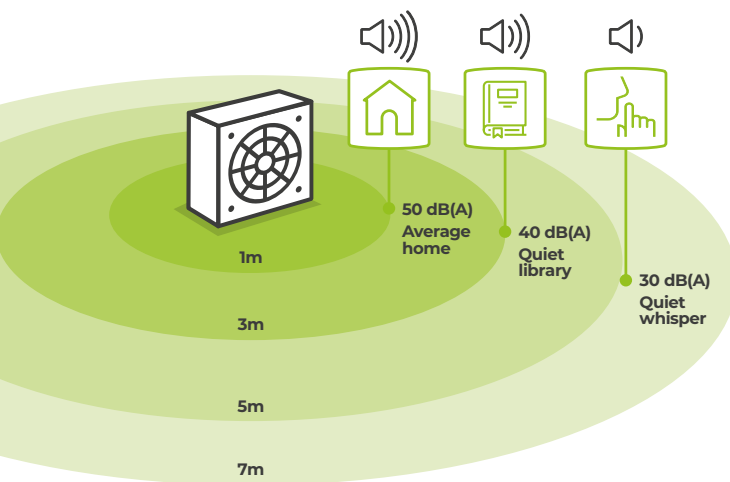

SOUND POWER

The way we calculate the sound a heat pump makes is by measuring the sound power and sound pressure. The sound power level is the sound that is emitted from the unit in laboratory conditions and is displayed on the ErP label.

SOUND PRESSURE

The sound noise level (sound pressure) measures the level of sound that you hear above the sound that already exists in the background. Sound pressure is lower than sound power.

QUIET MARK

The Logic Air range of heat pumps have all achieved Quiet Mark certification. Quiet mark is associated with the noise abatement society and technically assesses and certifies the quietest heat pumps in the heating industry.

COP & SCOP measures of efficiency.

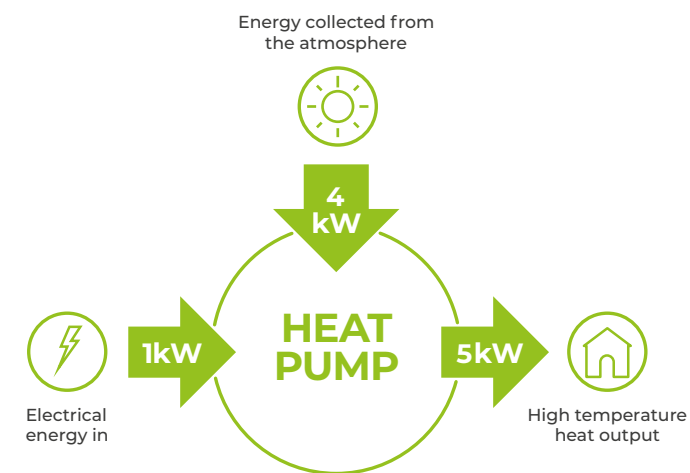

COP - COEFFICIENT OF PERFORMANCE

The coefficient of performance (COP) helps us measure the efficiency of a heat pump. The COP calculates the amount of heat energy a heat pump can create from each unit of electricity it uses.

$$\text{COP} = \frac{\text{HEAT OUTPUT}}{\text{ELECTRICAL INPUT}}$$

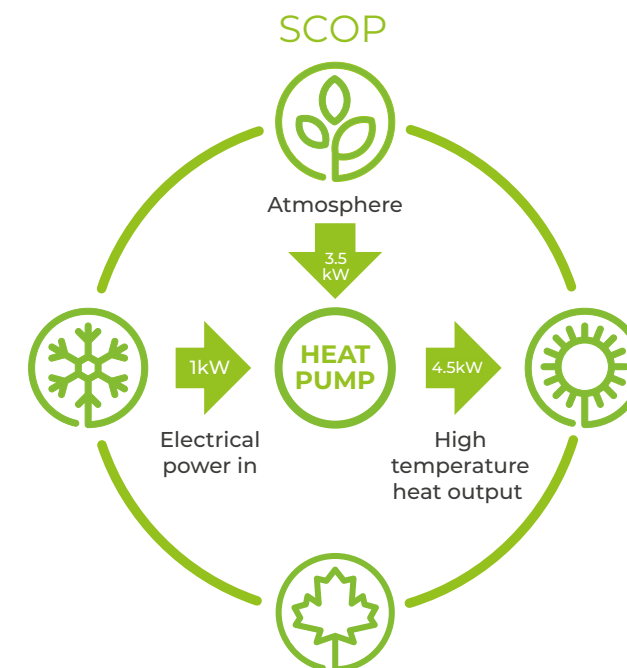

SCOP - SEASONAL COEFFICIENT OF PERFORMANCE

The seasonal coefficient of performance (SCOP) is the average COP carried over the annual heating season (the full year).

Logic Air pre-plumbed cylinder.



KEY FEATURES



150ltr - 300ltr
options



Industry leading
reheat times



Designed to fit
in UK homes



Control box
included



Built in low
loss header or
buffer tank



Fully pre-plumbed
and pre-wired

Pre-plumbed cylinder specification.

Our stainless steel Logic Air pre-plumbed hot water cylinders combine efficiency with practicality. Designed and manufactured in the UK and boasting industry leading reheat times, our cylinders have been designed to store and generate hot water efficiently using a heat pump.

The pre-plumbed cylinders remove and reduce the complexity and cost of a traditional heat pump installation. Our cylinders are completely pre-plumbed in our UK factory, everything from the three-port valve to the filter are pre-fitted, saving time and space during installation. The cylinders are also pre-wired, from pipe sensors to the thermostatic cut-out, optimising installation and increasing reliability.

NEW COMBINED DHW AND BUFFER CYLINDERS

The new pre-plumbed cylinder range includes models with an integrated buffer. Housing the DHW cylinder and separate buffer tank in the same case, alongside pre-wired circulation pumps and all the standard pre-plumbing components.

NEW LOW LOSS HEADER

Our new pre-plumbed low loss header cylinders de-couple the heating system from the heat pump protecting flow rates and enabling two zone control.

KEY FEATURES

✓ Industry leading reheat times

✓ Control box included

✓ Fully pre-plumbed and pre-wired

THE PRE-PLUMBED CYLINDER

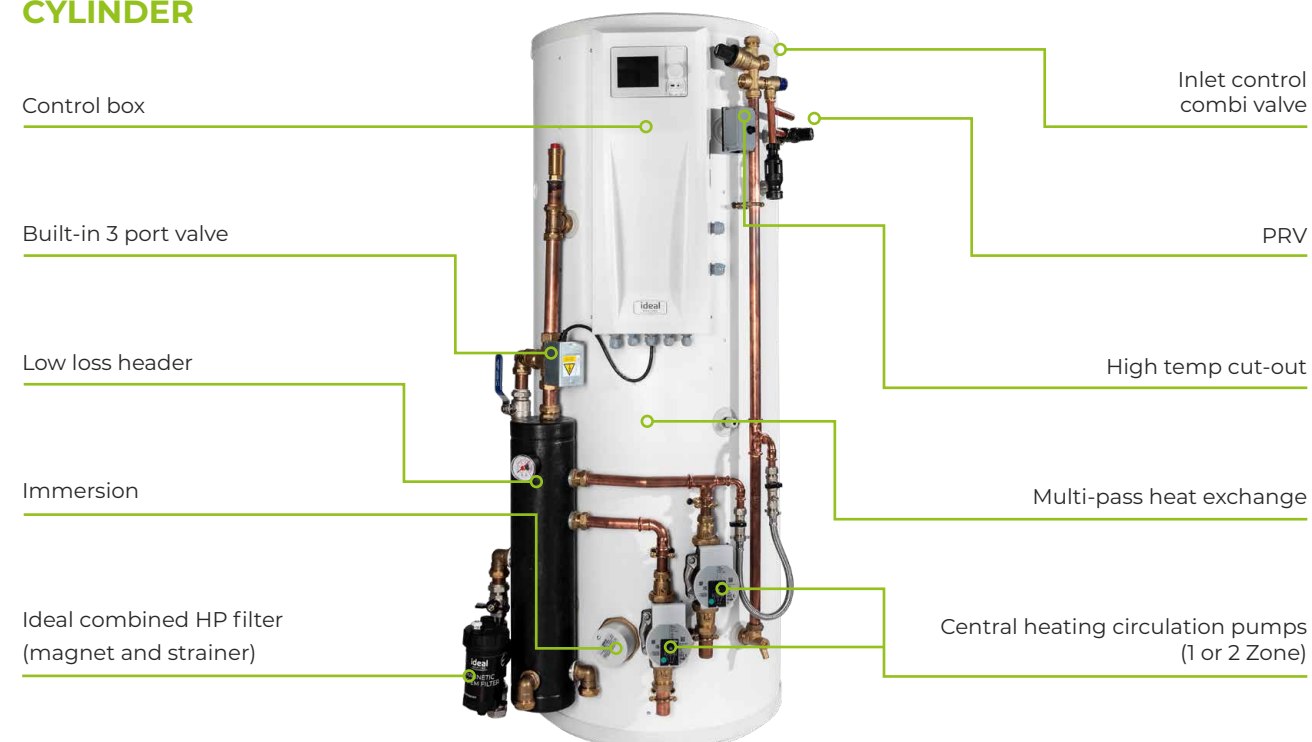

*Performance figures from for HWA 002:2020 heat pump test results



Single zone pre-plumbed cylinder specification.

Single zone pre-plumbed cylinder.

LOGIC AIR SINGLE ZONE PRE-PLUMBED CYLINDERS

		LOGIC AIR DHW CYL PP 150 CBOX 1Z SL	LOGIC AIR DHW CYL PP 180 CBOX 1Z SL	LOGIC AIR DHW CYL PP 150 CBOX 1Z	LOGIC AIR DHW CYL PP 180 CBOX 1Z
Ideal Product Code		236203	236204	236198	236199
Energy Efficiency Class		B	C	B	B
Heat Loss	Watts/h	50	58	44	49
Capacity (DHW content)	Litres	145	169	148	170
Weight Empty	kg	46	53	44	48
Weight Full	kg	192	222	192	219
Overall Width	mm	581	581	636	636
Overall Height	mm	1598	1870	1196	1384
Overall Depth	mm	606	606	683	683
Cylinder Diameter	mm	475	475	550	550
Cylinder Height	mm	1519	1791	1118	1306
Primary heat exchanger surface area	m ²	1.8	3.0	1.6	2.5
Heat up time from 10°C to 50°C*	min	22.26	21.81	22.56	22.56
Immersion Heater rating	kW	3	3	3	3

*Heat Up Time, HWA Heat Pump Test 002:2020 (flow rate 0.42l/s and flow temperature of 55°C)

INCLUDES

- ✓ Control Box
- ✓ Heat Pump Filter
- ✓ DHW 3-port Valve
- ✓ P&T Valve
- ✓ High Temp Cut Out
- ✓ Expansion Vessel
- ✓ Pressure Gauge
- ✓ Automatic Air Vent(s)
- ✓ Isolation Valves
- ✓ 3kW Immersion
- ✓ Flow Thermistors
- ✓ DHW Thermistor
- ✓ Outdoor Sensor

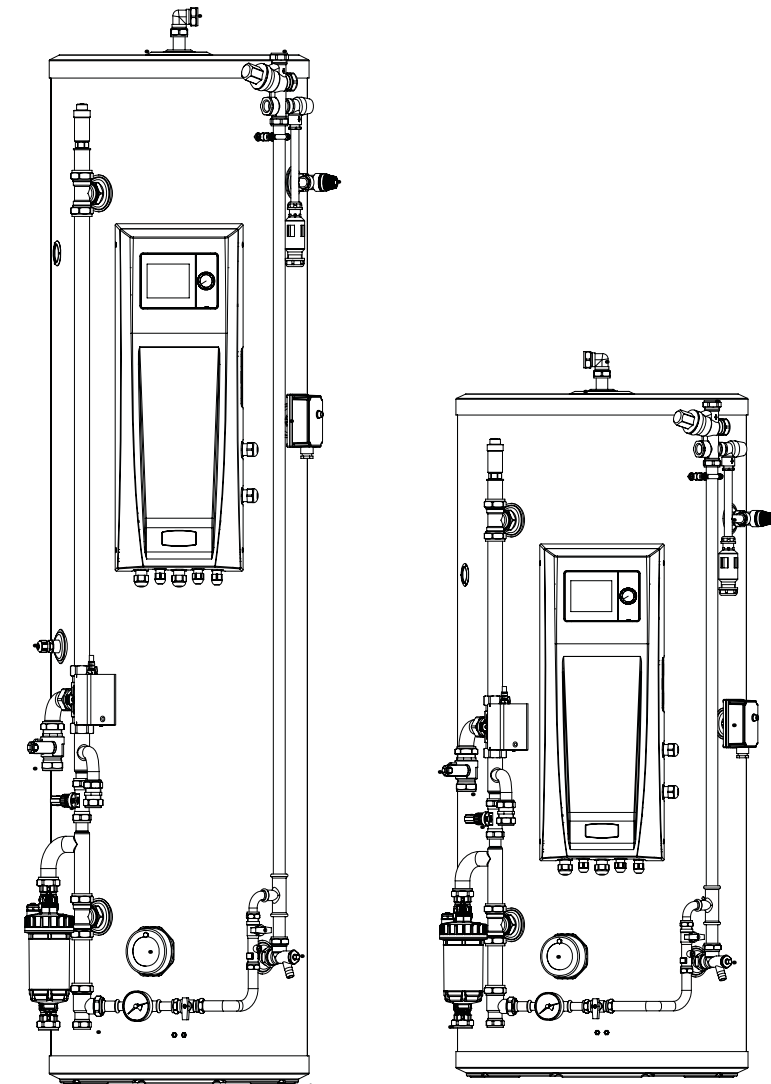

Two zone pre-plumbed cylinder specification.

LOGIC AIR TWO ZONE PRE-PLUMBED CYLINDERS WITH LOW LOSS HEADER

		LOGIC AIR DHW CYL PP 210 CBOX LL 2Z SL	LOGIC AIR DHW CYL PP 210 CBOX LL 2Z	LOGIC AIR DHW CYL PP 250 CBOX LL 2Z	LOGIC AIR DHW CYL PP 300 CBOX LL 2Z
Ideal Product Code		236205	236200	236201	236202
Energy efficiency class		C	B	C	C
Heat loss	Watts/h	65	55	63	72
Capacity (DHW content)	Litres	188	199	237	279
Weight empty	kg	60.6	64	69.8	73.4
Weight full	kg	248.9	262.8	307	352.4
Overall width	mm	647	704	704	704
Overall height	mm	2042	1572	1822	2068
Overall depth	mm	620	686	686	686
Cylinder diameter	mm	475	550	550	550
Primary heat exchanger surface area	m ²	2.5	2.5	3.0	3.0
Secondary return connection		yes	yes	yes	Yes
Immersion heater rating	kW	3	3	3	3
Heat up time from 10°C to 50°C*	min	23.68	30.60	27.34	35.05

*Heat Up Time, HWA Heat Pump Test 002:2020 (flow rate 0.42l/s and flow temperature of 55°C)

INCLUDES

- ✓ Control Box
- ✓ Wiring Centre
- ✓ Controller
- ✓ Low Loss Header
- ✓ Heat Pump Filter
- ✓ DHW 3-port Valve
- ✓ P&T Valve
- ✓ High Temp Cut Out
- ✓ Expansion Vessel
- ✓ Pressure Gauge
- ✓ Automatic Air vent(s)
- ✓ Isolation Valves
- ✓ 3kW Immersion
- ✓ x2 Circulation Pumps
- ✓ Flow Thermistors
- ✓ DHW Thermistor
- ✓ Outdoor Sensor

Two zone pre-plumbed cylinder.

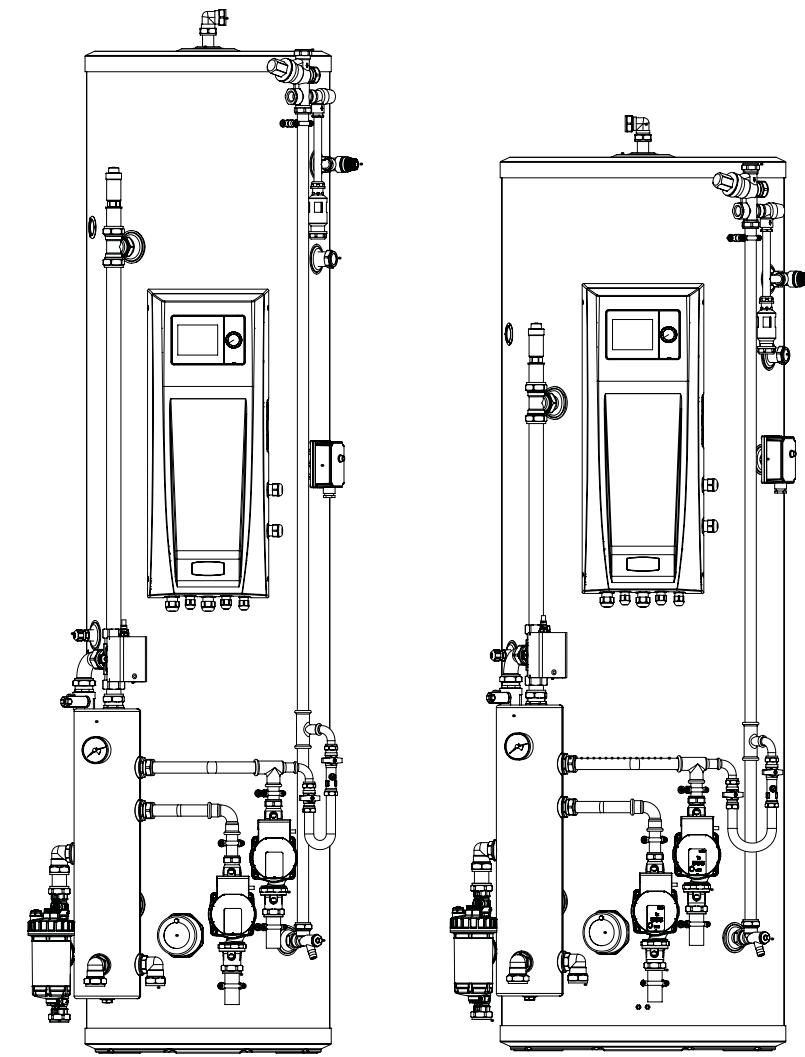

Pre-plumbed DHW cylinders with **integrated buffer** single zone specification.

PRE-PLUMBED DHW CYLINDER WITH INTEGRATED BUFFER - SINGLE ZONE

		LOGIC AIR DHW CYL PP 180 CBOX BUFF 1Z	LOGIC AIR DHW CYL PP 210 CBOX BUFF 1Z	LOGIC AIR DHW CYL PP 250 CBOX BUFF 1Z	LOGIC AIR DHW CYL PP 300 CBOX BUFF 1Z
Ideal Product Code		236206	236208	236210	236212
Energy efficiency class		B	B	B	B
Heat Loss	Watts/h	49	55	62	68
Capacity (DHW content)	Litres	171	199	239	287
Volume of integrated buffer	Litres	70	70	63.5	63.5
Weight empty	Kg	64.6	68.6	77	87
Weight full	Kg	305.6	337.4	379	437.5
Overall width	mm	644	644	705	705
Overall height	mm	1907	2095	1908	2128
Overall depth	mm	702	702	780	780
Cylinder diameter	mm	550	550	630	630
Cylinder height	mm	1829	2017	1829	2049
Primary heat exchanger surface area	m2	2.5	2.5	2.5	3.0
Heat up time from 10°C to 50°C**	Min	22.17	32.71	26.56	44.09
Immersion heater rating	kW	3	3	3	3
Secondary return connection	No/Yes	No	Yes	Yes	Yes

*Heat Up Time, HWA Heat Pump Test 002:2020 (flow rate 0.42l/s and flow temperature of 55°C).

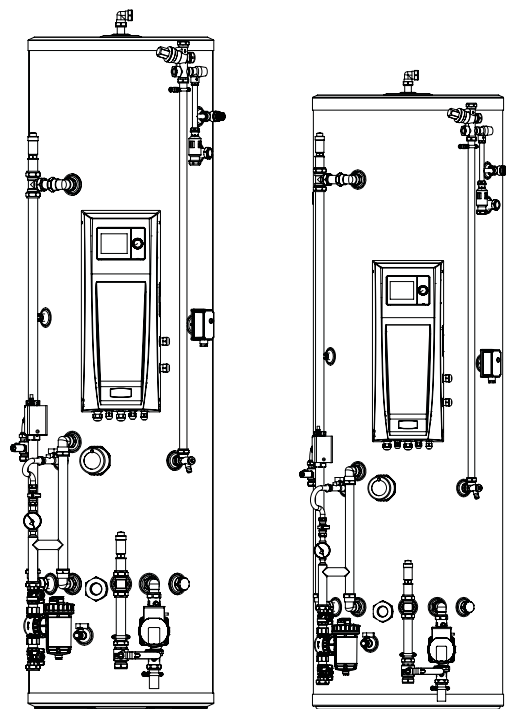

INCLUDES

- ✓ Control Box
- ✓ Buffer Tank
- ✓ Heat Pump Filter
- ✓ DHW 3-port Valve
- ✓ P&T Valve
- ✓ High Temp Cut Out
- ✓ Expansion Vessel
- ✓ Pressure Gauge
- ✓ Automatic Air Vent(s)
- ✓ Isolation Valves
- ✓ 3kW Immersion
- ✓ Circulation Pump
- ✓ Flow Thermistors
- ✓ DHW Thermistor
- ✓ Outdoor Sensor

Pre-plumbed DHW cylinders with **integrated buffer** two zone specification.

PRE-PLUMBED DHW CYLINDER WITH INTEGRATED BUFFER - TWO ZONE

		LOGIC AIR DHW CYL PP 180 CBOX BUFF 2Z	LOGIC AIR DHW CYL PP 210 CBOX BUFF 2Z	LOGIC AIR DHW CYL PP 250 CBOX BUFF 2Z	LOGIC AIR DHW CYL PP 300 CBOX BUFF 2Z
Ideal Product Code		236207	236209	236211	236213
Energy efficiency class		B	B	B	B
Heat Loss	Watts/h	49	55	62	68
Capacity (DHW content)	Litres	171	199	239	286
Volume of integrated buffer	Litres	70	70	63.5	63.5
Weight empty	Kg	68	71.8	80	90.2
Weight full	Kg	309	340.6	382	439.7
Overall width	mm	644	644	705	705
Overall height	mm	1907	2095	1908	2128
Overall depth	mm	702	702	780	780
Cylinder diameter	mm	550	550	630	630
Cylinder height	mm	1829	2017	1829	2049
Primary heat exchanger surface area	m2	2.5	2.5	2.5	3.0
Heat up time from 10°C to 50°C**	Min	22.17	32.71	26.56	44.09
Immersion heater rating	kW	3	3	3	3
Secondary return connection	No/Yes	No	Yes	Yes	Yes

*Heat Up Time, HWA Heat Pump Test 002:2020 (flow rate 0.42l/s and flow temperature of 55°C).

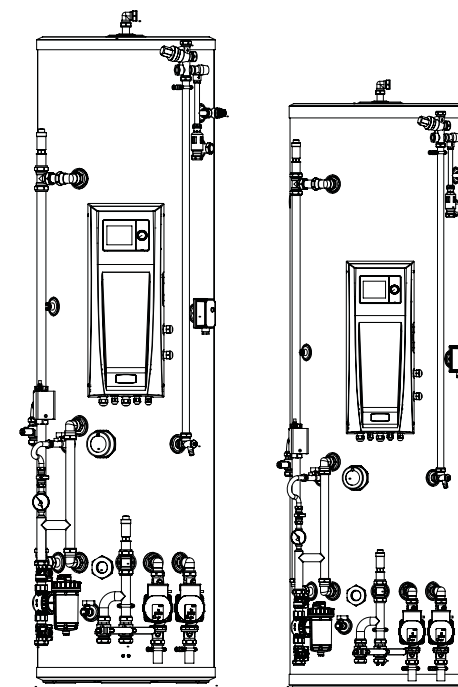

INCLUDES

- ✓ Control Box
- ✓ Buffer Tank
- ✓ Heat Pump Filter
- ✓ DHW 3-port Valve
- ✓ P&T Valve
- ✓ High Temp Cut Out
- ✓ Expansion Vessel
- ✓ Pressure Gauge
- ✓ Automatic Air Vent(s)
- ✓ Isolation Valves
- ✓ 3kW Immersion
- ✓ Circulation Pump(s)
- ✓ Flow Thermistors
- ✓ DHW Thermistor
- ✓ Outdoor Sensor

Logic Air control box.



The Logic Air control box is the central hub for the heat pump system, linking the heat pump to your heating and hot water cylinder. It enables in depth control, scheduling, connectivity and performance diagnostics.

INBUILT HEAT PUMP CONTROLLER

Our inbuilt controller uses tried and tested technology to keep you warm efficiently. From scheduling to diagnostics our controller gives you control and transparency.

QUICK START SET UP

Our new quick start menu makes commissioning fast, easy and accurate. In just a few steps the heat pump can be up and running and tuned to its most efficient parameters.

HYBRID READY

For installations that require a heat pump and a boiler, the Logic Air control box brings a boiler and heat pump together seamlessly.

CONNECTIVITY

The Logic Air control box is compatible with Halo Air, Link Cellular heat pump diagnostics and 3rd party thermostats, giving you access to online control, scheduling and remote diagnostics from anywhere in the world.

SMART GRID COMPATIBLE / SOLAR PV COMPATIBLE

The Logic Air control box is smart grid ready and can connect to solar PV, enabling smarter ways of powering heating and hot water.

PERFORMANCE DIAGNOSTICS

The Logic Air control box gives you access to the efficiency of the householders heating system, helping them to understand the health of their heat pump system at a glance.



Control box		Ideal Product Code: 235797	
Physical properties			
Weight	kg	5	
Height	mm	627	
Width	mm	254	
Depth	mm	147	
Electrical properties			
IP rating	IP	20	
Rated voltage	VAC	220-240	
Maximum rated current (control box)	A	1	
Maximum rated current (contactor)	A	16	
Rated power input (control box)	W	100	
Rated power input (contactor)	W	3000	

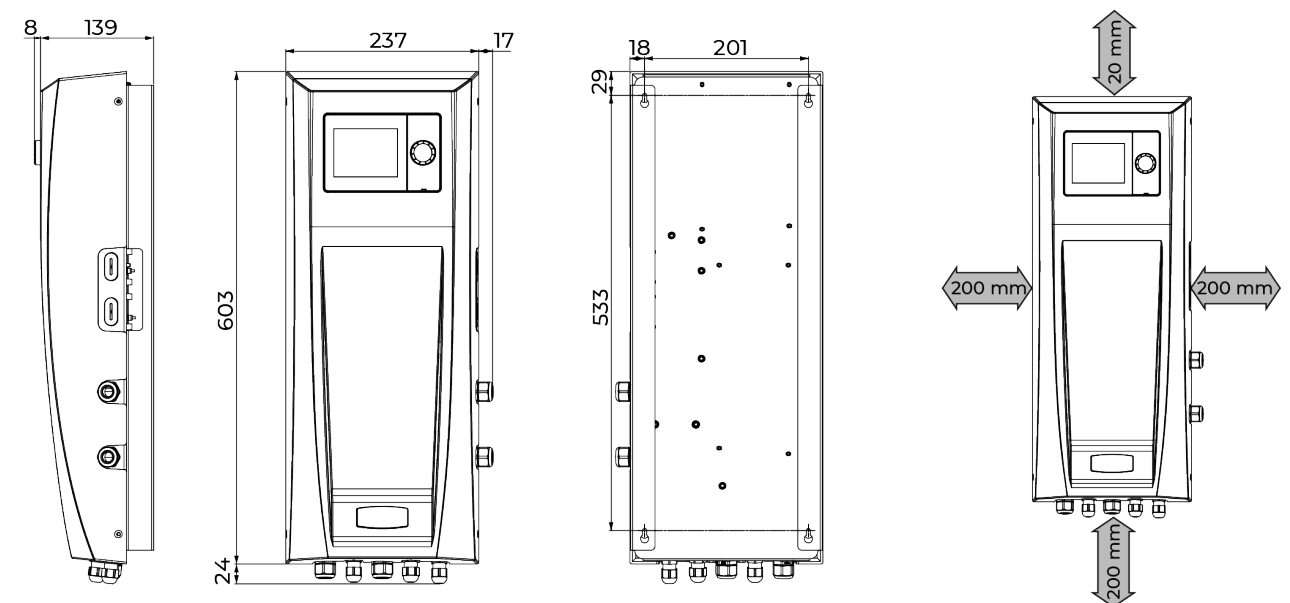

Accessories list.



FLEXIBLE HOSE

Ideal Product Code: 236909

Flexible Hose 500mm

- 28mm -1" Female connections pair (2x hose)
- Pre-insulated (19mm PVC)
- Stainless steel

Ideal Product Code: 236910

Flexible Hose 750mm

- 28mm -1" Female connectionsPair (2x hose)
- Pre-insulated (19mm PVC)
- Stainless steel



BUFFER TANK

Ideal Product Code: AH700436

25L Buffer Tank

- 1" and 1 1/4 connections
- 6 bar max. pressure

Ideal Product Code: AH700437

50L Buffer Tank

- 1" and 1 1/4 connections
- 6 bar max. pressure



MAGNETIC FILTER

Ideal Product Code: 236911

- 28mm connections
- 4 bar max. working pressure

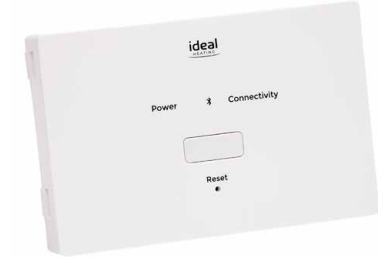

LINK DIAGNOSTICS CELLULAR HEAT PUMP

Ideal Product Code: 235545

- Remote Diagnostics
- Online Dashboard
- Designed for Logic Air
- 10 year data plan included

ACCESSORIES FOR OUTDOOR UNIT.



ANTI-VIBRATION RUBBER MOUNTING FEET

Ideal Product Code: AH809536

- Rubber feet
- Pair (x2)
- 600mm



FILTER BALL VALVE

Ideal Product Code: 236738

- 1" connections
- 30 bar max. pressure
- Brass – chrome plated body
- Stainless steel & Nylon filter



Y STRAINER

Ideal Product Code: 236740

- 1" connections
- 16 bar max. pressure
- Brass body
- Stainless steel strainer

*The product images shown are for illustration purposes only and may not be an exact representation of the product

HALO

AIR

IDEAL HALO AIR Wi-Fi & RF



KEY FEATURES



Designed for
Logic Air



Easy to install



Full heating and
hot water control



*2 year parts and labour warranty available when registered within 30 days of installation. Terms and conditions apply.

Halo Air introduction.

Halo Air is a programmable room thermostat, based on the current Ideal Halo platform that is designed and developed to work seamlessly with the new Logic Air monobloc heat pump.

As the primary interface with the end user for the whole heating system it is important that the room thermostat is clear, easy to use and guides the right usage behaviour.

Halo Air not only provides a clear user interface for the householder but it helps to communicate diagnostic data to the installer or service help desk.

HALO AIR RF.



HALO AIR WI-FI.



HALO AIR 2 ZONE RF.



HALO AIR 2 ZONE WI-FI.



Halo Air RF.



2

YEAR WARRANTY*



2 year warranty



Easy to install



Load compensating control



Compatible with Logic Air



Simple wiring connections to heat pump control box



Simple dial and button interface

Halo Air RF is a wireless programmable room thermostat designed specifically to work with Logic Air.

Halo Air offers fast, flexible and intelligent wireless technology and is packed with features that enable simple and easy heating and hot water control.

Ideal product code	234819
Power source	4 x AA alkaline batteries or USB
Wireless communication protocol	Zigbee 3.0
Heat pump communication protocol	BSB
Install location	Wall mounted or desk mounted
Desk stand supplied	YES
ERP Class	Class VI
TTZC (Time, Temperature and Zone control)	YES - Time and Temperature control
WEEE	Yes - options available
Certification	UKCA CE

*2 year parts and labour warranty available when registered within 30 days of installation. Terms and conditions apply.

Halo Air Wi-Fi.



2

YEAR WARRANTY*



2 year warranty



Smart home compatible



Control your heating and hot water anywhere via the app



Compatible with Logic Air



Easy to install



Smart support from Ideal customer service



Easy app set up



Load compensating control

Halo Air Wi-Fi is engineered specifically to work with Logic Air heat pumps and allows flexible control of heating and hot water with the intuitive Halo app, which can be connected through smart home devices like Amazon Alexa and Google Home.

It's simple to install, straightforward for everyone to use, no matter where they are.

Ideal product code	234790
Power source	4 x AA alkaline batteries or USB
Wireless communication protocol	Zigbee 3.0
Heat pump communication protocol	BSB
Install location	Wall mounted or desk mounted
Desk stand supplied	YES
ERP Class	Class VI
TTZC (Time, Temperature and Zone control)	YES - Time and Temperature control
WEEE	Yes - options available
Certification	UKCA CE

*2 year parts and labour warranty available when registered within 30 days of installation. Terms and conditions apply.

Halo Air 2-Zone RF.

2
YEAR WARRANTY*



2-Zone control



Easy to install



Load compensating control



Compatible with Logic Air



Simple wiring to heat pump control box



Simple dial and button interface

Halo Air RF 2-Zone incorporates an additional programmable room thermostat with the extra functionality of controlling the temperature of a second zone.

Ideal product code	234791
Power source	8 x AA alkaline batteries or USB
Wireless communication protocol	Zigbee 3.0
Heat pump communication protocol	BSB
Install location	Wall mounted or desk mounted
Desk stand supplied	YES
ERP Class	Class VI
TTZC (Time, Temperature and Zone control)	YES - Time, temperature and Zonal control
WEEE	Yes - options available
Certification	UKCA CE

*2 year parts and labour warranty available when registered within 30 days of installation. Terms and conditions apply.

Halo Air 2-Zone Wi-Fi.

2
YEAR WARRANTY*



2-Zone control



Smart home compatible



Control your heating and hot water no matter where you are



Compatible with Logic Air



Easy to install



Smart support from Ideal customer service



Easy app set up



Load compensating control

Halo Air Wi-Fi 2-Zone incorporates an additional programmable room thermostat with the extra functionality of controlling the temperature of a second zone.

Ideal product code	234792
Power source	8 x AA alkaline batteries or USB
Wireless communication protocol	Zigbee 3.0
Heat pump communication protocol	BSB
Install location	Wall mounted or desk mounted
Desk stand supplied	YES
ERP Class	Class VI
TTZC (Time, Temperature and Zone control)	YES - Time, temperature and Zonal control
WEEE	Yes - options available
Certification	UKCA CE

*2 year parts and labour warranty available when registered within 30 days of installation. Terms and conditions apply.

Halo Air features.

HALO AIR IS A BATTERY POWERED, WIRELESS CONTROL FOR BOTH HEATING AND HOT WATER.

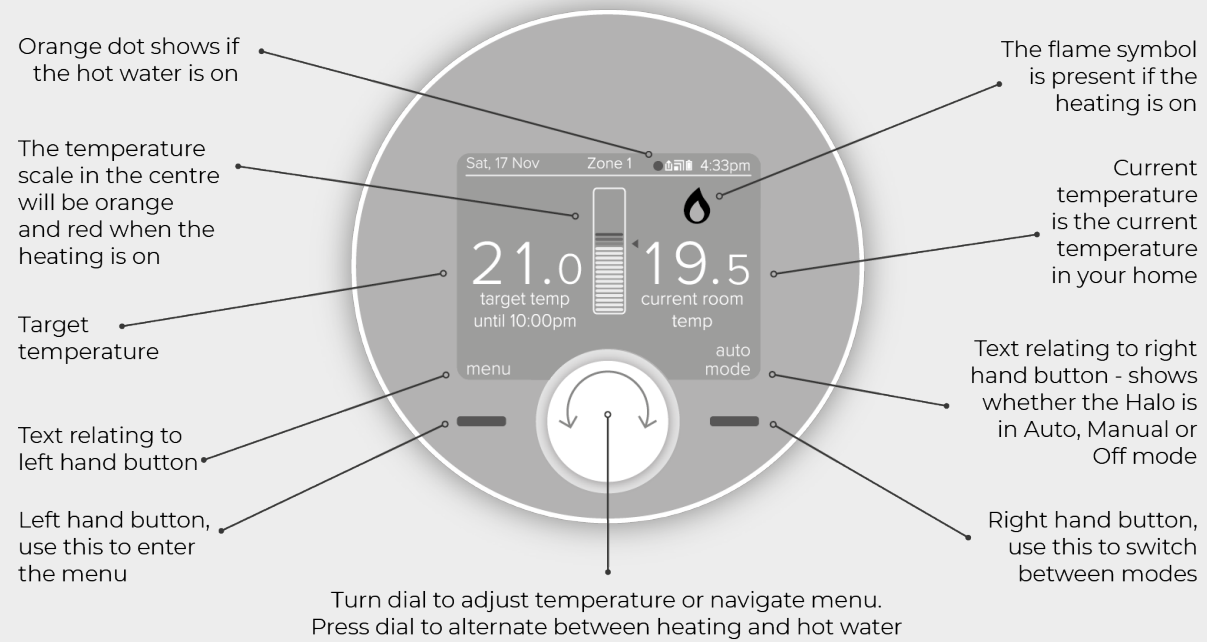

HALO AIR SMART INTERFACE

The Halo Air smart interface connects the heat pump to the Wi-Fi and the Halo thermostat(s)

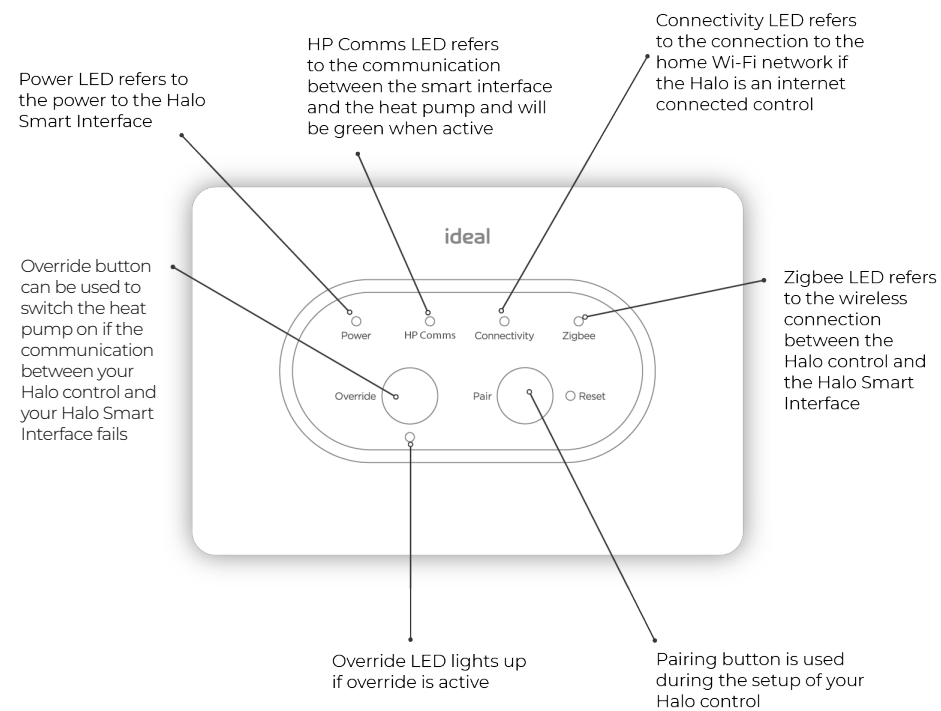

Logic Air and Halo Air product codes.

Ideal Product Code	Description
Logic Air monobloc heat pumps	
AH750665	Logic Air monobloc 5kW R32
AH750666	Logic Air monobloc 8kW R32
AH750667	Logic Air monobloc 10kW R32
Halo Air programmable room thermostat	
234819	Halo Air single zone RF
234790	Halo Air single zone Wi-Fi
234791	Halo Air 2-zone RF
234792	Halo Air 2-zone Wi-Fi
Pre-plumbed DHW cylinder with control box and integrated buffer tank	
236206	Logic Air DHW pre-plumbed cylinder 180L, control box & buffer 1-zone
236207	Logic Air DHW pre-plumbed cylinder 180L, control box & buffer 2-zone
236208	Logic Air DHW pre-plumbed cylinder 210L, control box & buffer 1-zone
236209	Logic Air DHW pre-plumbed cylinder 210L, control box & buffer 2-zone
236210	Logic Air DHW pre-plumbed cylinder 250L, control box & buffer 1-zone
236211	Logic Air DHW pre-plumbed cylinder 250L, control box & buffer 2-zone
236212	Logic Air DHW pre-plumbed cylinder 300L, control box & buffer 1-zone
236213	Logic Air DHW pre-plumbed cylinder 300L, control box & buffer 2-zone
Pre-plumbed DHW cylinders with control box	
236198	Logic Air DHW pre-plumbed cylinder 150L & control box 1-zone
236199	Logic Air DHW pre-plumbed cylinder 180L & control box 1-zone
236200	Logic Air DHW pre-plumbed cylinder 210L, control box & low loss header 2-zone
236201	Logic Air DHW pre-plumbed cylinder 250L, control box & low loss header 2-zone
236202	Logic Air DHW pre-plumbed cylinder 300L, control box & low loss header 2-zone
236203	Logic Air DHW pre-plumbed slimline cylinder 150L & control box 1-zone
236204	Logic Air DHW pre-plumbed slimline cylinder 180L & control box 1-zone
236205	Logic Air DHW pre-plumbed slimline cylinder 210L, control box & low loss header 2-zone

Ideal Product Code	Description
Non pre-plumbed DHW heat pump cylinders	
219433	Heat pump cylinder 180L
219437	Heat pump cylinder 180L slimline
219434	Heat pump cylinder 210L
219438	Heat pump cylinder 210L slimline
219435	Heat pump cylinder 250L
219436	Heat pump cylinder 300L
Logic air standalone control	
235797	Logic Air control box
Buffer tanks	
AH700436	Buffer tank 25L
AH700437	Buffer tank 50L
Accessories	
AH809536	Rubber floor standing feet 600mm (x2)
236909	Flexible hose 500mm
236910	Flexible hose 750mm
236738	Filter ball valve
236740	Y strainer
236911	Logic Air magnetic system filter
235545	Link Diagnostics Cellular Heat Pump



Designed for new builds.



MONOBLOC TECHNOLOGY

- Modern contemporary chassis design
- Quiet acoustics
- Easy to install and service
- Simple to commission
- Designed for Halo Air



DHW PERFORMANCE MATTERS

- Designed to work with Logic Air pre-plumbed cylinders
- Highly efficient hot water production
- Fast reheat times for reduced energy usage
- Low pressure losses ensure good heat pump modulation



GOING GREEN WITHOUT COMPROMISE

- Built to be efficient with an A+++ ErP rating
- Capacities to work in the UK climate
- R32 refrigerant with zero ozone depletion and low global warming potential
- Integrates with solar PV and smart grid technologies



USER FRIENDLY

- Simple user controls
- Low running costs
- Easy maintenance and installation
- Engineered for reliability



INDUSTRY LEADING CUSTOMER SERVICE

- In house heat pump design team
- Nationwide service engineers
- UK customer service contact centre
- Online warranty registration with Connect



CUTTING EDGE TECHNOLOGY

- Auto Adapt - Autopilot for your heating
- Engineered for reliability
- Remarkably quiet



Designed for installers.



QUICK INSTALLATION

- Small and compact
- Low clearances
- One 4-core cable between the heat pump and control box
- Pre-plumbed and pre-wired heat pump cylinder



EASY SERVICING AND MAINTENANCE

- Remote system health checks
- Factory fitted magnetic and particle filter
- All service components to one side of the heat pump
- All hydraulic servicing can be done inside the property



WORLD-CLASS SUPPORT

- Dedicated heat pump engineers covering every corner of the UK
- First install assisted commissioning
- Full parts and labour warranty
- UK based contact centre 364 days a year

Benefits of working with Ideal.



At Ideal Heating we are committed to delivering the highest level of customer service. With more than 100 years' experience in the heating industry, we know how important confidence and trust are to our customers.



With a range of tools to help you grow your business, Ideal is on hand to ensure you have the support you need. Our dedicated customer service department is available 364 days a year.



We also have a team of expert engineers, fully trained to exacting standards, on hand to provide one-to-one advice on the road, over the phone or online ensuring you're fully supported, wherever and whenever you need.

World-class support.

Best-in-class heat pump engineer support.

- Nationwide customer service engineers
- Dedicated expert heat pump engineers to ensure you have the support you need
- On hand to provide one-to-one advice on the road, over the phone or online
- You're fully supported, wherever and whenever you need

Products designed to work together.

- The Logic Air heat pump takes all the experience we have across the globe and throughout Europe to deliver heat pump technology that works and provides optimum comfort and efficiency
- The Ideal heat pump package combines three revolutionary products: Our quiet, compact and highly efficient monobloc heat pump, our industry leading pre-plumbed heat pump cylinder and the Halo Air heat pump thermostat
- Designed in the UK for the UK by our in house experts
- Ensuring a fit for purpose heating system

Dedicated heat pump customer service.

- Over £4 million investment into our services to support you
- Our highly trained customer service have expertise across the full product range
- UK based contact centre 364 days a year
- Delivering industry leading customer support

Remote system health checks.

- Simple and quick heat pump health checks
- Quick and easy no call out remote system resets
- Smart support for peace of mind

* System needs to be connected through Halo Air WiFi or Link Cellular for remote system health checks.



Customer Service:

01482 498660

Technical Help:

01482 498663

Ideal Heating, PO Box 103, National Avenue,
Kingston upon Hull, East Yorkshire, HU5 4JN

E: enquiries@idealheating.com

idealheating.com |     

The information in this brochure was correct at the time of going to print. Ideal Heating reserve the right to make any modifications to product specifications or any other details, without prior notification. For further clarification, please enquire in writing to the head office address above.

